

Model 765-16B

Portable Barometric Standard



The **Model 765-16B** is the best choice for accurate, reliable and stable barometric pressure measurements. The integral Digiquartz® Barometers have been extensively used in field transfer standards for ASOS and AWOS verification, meteorological measurement systems, altimeter setting indicators, air data test sets, and other critical applications such as GPS-Meteorology, infrasonic research, atmospheric wave and turbulence detection, and geophysical studies.

The **Model 765-16B** is portable, easy to use and fully self-contained in a rugged, compact case. Turn it on and immediately read barometric pressure in any desired engineering units. Front panel selections include taring, resolution, sampling time, number of display digits, engineering units, max-min readings, alarm points, and communication parameters. Choices for the second line display include an analog pressure bar graph, sensor temperature, rate of pressure change, stored text or user-defined external text.

Special Barometric Functions available on the second line display include Field Pressure, Station Pressure, Altimeter Setting, Sea-Level Pressure, Density Altitude, Pressure Altitude, Q Signals - QNH & QNE, and WMO Pressure Tendency Codes.

An internal logger can automatically store over 390000 high-resolution data points. The Model 765 can also be controlled via the bi-directional RS-232 or USB interface with a new, improved command set. The unit is either continuously powered from its AC adapter or for up to 150 hours from the internal rechargeable battery.

PERFORMANCE

0.0001% resolution (<1 microbar resolution)
±0.08 hPa or better accuracy
0.1 hPa/year or better stability

RANGES

500 hPa to 1100 hPa (14.7 to 32.5 in Hg)
Contact factory for wider ranges

APPLICATION AREAS

Meteorology	Avionics Testing
Oceanography	Process Control
Transfer Standards	Airfield Operations
Weather Monitoring	Infrasonic Applications

FEATURES

- Barometric functions
 - Altimeter Setting
 - Field Pressure
 - Station Pressure
 - Sea-Level Pressure
 - Density Altitude
 - Pressure Altitude
 - Q Signals – QNH, QFE
 - WMO Tendency Codes
- Simple, intuitive front panel menu system
- Tare, Hold and Programmable Fast Key
- Front panel data entry and display
- Password-protected menu system
- Two-line backlit display– Menu selectable functions
- Taring
- Engineering units
- Sensor temperature
- Resolution and sampling speed
- Maximum and minimum pressure
- Average pressure, rate, trend and scatter functions
- Free configuration and logging software
- Internal data logging - over 390000 data points
- Edit data via the front panel
- Remaining memory display
- Burst mode above selected threshold
- Enhanced remote control and command
- User-defined outputs
- USB and RS-232 interfaces
- High and low pressure alarm points
- Internal rechargeable battery or AC power
- 100-240 VAC universal power adapter
- Battery status LED and display indicator
- 150 hours rechargeable battery operation
- Easy upgrades to embedded software

QUALITY AND STANDARDS

ISO 9001:2000 Quality System
NIST traceable - CE compliant
3-year 0.1 hPa/year stability warranty
Market-leading 5-year limited transducer warranty

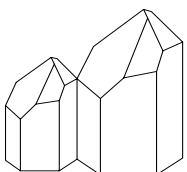

Paroscientific, Inc.
Digiquartz® Pressure Instrumentation



Model 765-16B

Portable Barometric Standard

PERFORMANCE

Resolution0.0001% (<1 microbar)
Accuracy ± 0.08 hPa or better.⁽¹⁾
Stability 0.1 hPa /year or better⁽²⁾⁽³⁾
Range 500-1100 hPa (14.7-32.5 in Hg)
Consult factory for wider ranges

CHARACTERISTICS

Weight 8.5 lb (3.86 Kg) Typical
Power Requirements 100-240 VAC (Up to 150 hours on internal rechargeable battery)

ENVIRONMENTAL

Overpressure 1240 hPa (36.6 in Hg)
Operating Temp. Range -20 °C to +50 °C (-4 °F to +122 °F)

ACCESSORIES

Accessories include USB cable, manual, power adapter, menu card and software CD.

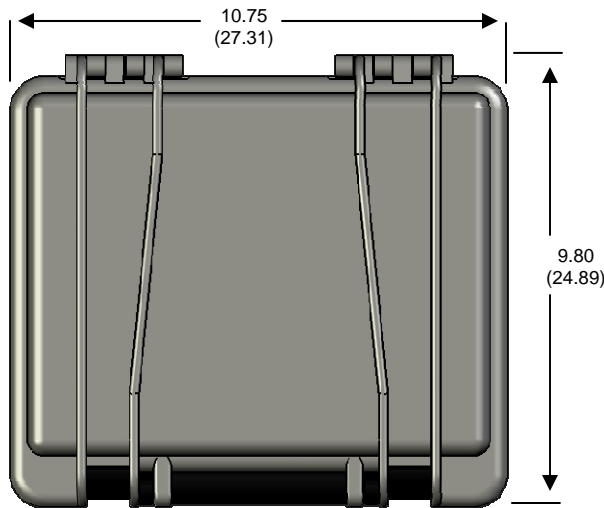

Dimensions are in inches - parenthesized dimensions are in centimeters

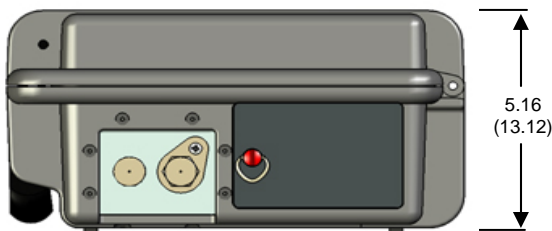

- (1) Accuracy relative to the primary standard includes resolution, hysteresis, non-repeatability and non-conformance.
- (2) 3-year 0.1 hPa/year stability warranty.
- (3) One free zero adjustment included within 2 years of shipment.



Paroscientific, Inc.

4500 148th Ave. N.E.
Redmond, WA, USA 98052
www.paroscientific.com

HIGH PERFORMANCE PRESSURE PORT

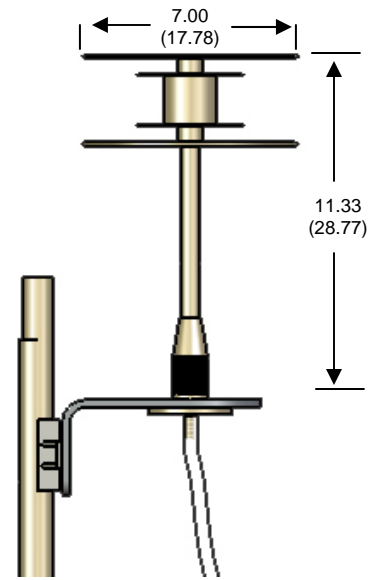

DigiPort

Accurate measurements of barometric pressure require an environmentally rugged pressure port design that minimizes pressure errors under dynamic wind conditions. Wind tunnel and field tests of the high-performance pressure port (DigiPort) used on the Paroscientific MET3A Meteorological System show superior performance over all other ports. Barometric readings with the MET3A pressure port system easily meet the requirements of GPS Meteorology, Weather Stations, Digital Altimeter Setting Indicators, High-Resolution Measurements of Atmospheric Waves, and Aircraft Wake-Turbulence Detection.

The high-performance DigiPort is now optionally available for use with the Model 765-16B Portable Barometric Standard and all other Digiquartz® Barometric Instruments. It provides barometric accuracy of better than 0.08 hPa in strong winds, all wind directions, pitch or tilt angles up to 25 degrees, rain, and freezing conditions. It outperforms open ports, single ports, single disks, shrouded pipes, closely spaced dual-disks, multi-hole probes, probes incorporating spheres or cones, and swiveling pitot tubes with static pressure inlets.

ORDERING INFORMATION

Model 765-16B Part Number: 1100-010
High Performance DigiPort Part Number: 1745-001

Telephone: (425) 883-8700
Facsimile: (425) 867-5407
E-mail: support@paroscientific.com